



## TrafficEmbedded

TrafficEmbedded is a **real-time video analysis** unit which turns any **IP camera** into a smart multipurpose sensor by just plugging in a cable. Based on deep neural networks, Embedded represents a new generation of **edge solutions** enabling all the features of a distributed video-analytics environment. It is powered by the **most advanced traffic analytic framework FLOW** which makes it an ideal choice for any monitoring and control task in the field of intelligent transport systems, smart cities, security or retail. Embedded comes in the form of a **small anti-vandal IP66-rated box** designed for easy outdoor installation on light poles. It supports multiple connectivity options including **LTE/5G** and **LORA/IoT**. Furthermore, it could be equipped with an I/O expander, V2X module or local data storage. The unit can also be remotely configured and updated.

### TrafficEmbedded Micro

- suitable for one/two directional traffic monitoring (straight segments)
- FLOW Insights, real-time processing, fully configurable, Open API, traffic events & alerts & evidence
- Xavier NX, up to 2 IP PoE+ cameras including PTZ

#### suitable for:

- highway traffic monitoring
- pedestrians & cyclists counting
- queue detection (traffic, retail)
- parking management
- wrong way detection
- speeding detection

### TrafficEmbedded Macro

- suitable for complex scenes such as intersections and roundabouts with mixed traffic
- FLOW Insights, real-time processing, fully configurable, Open API, traffic events & alerts & evidence
- Xavier AGX, up to 3 IP PoE+ cameras including PTZ

#### suitable for:

- road flow control
- adaptive traffic lights
- traffic violation reporting
- retail store heat maps, interactive stores
- U-turn detection
- perimeter protection (security)

## Powered by FLOW, the most powerful traffic framework

FLOW is a fully interactive video analytical traffic framework designed for real-time driven applications. It is the fastest and the most efficient way to transform any video stream into a stream of actionable insights. The first tool ever which visualizes traffic data live right at your fingertips and communicates with the other parts of your smart infrastructure using open APIs. FLOW is built for all thinkable traffic scenarios thanks to the powerful combination of unique visual traffic programming language, trajectory-driven design and AI-based image processing. Take the advantage of the one unified solution for smart traffic, parking, retail and security, which runs everywhere.

### Video detection features

FLOW is powered by a proprietary developed and globally trusted video analytical engine utilizing deep-learning. This engine is capable of detecting and tracking hundreds of objects in multi-camera environments simultaneously.

### Interactive data visualization

FLOW allows you to visualize the extracted information and analyses using interactive widgets on the customizable dashboards. Create a beautiful and live visualization of the current traffic situation.

### Traffic analysis functions

FLOW supports various traffic analytic functions and operators that can be combined into a comprehensive traffic analysis running in real-time. Thanks to the unique visual traffic programming language, you will be a designer of a monitoring solution tailored to your specific needs.

### Data interfaces

FLOW was born for integration with other parts of smart infrastructure. Any type of extracted traffic insights can be continuously delivered to 3rd party systems using an open API which supports multiple communication protocols including UDP and REST.

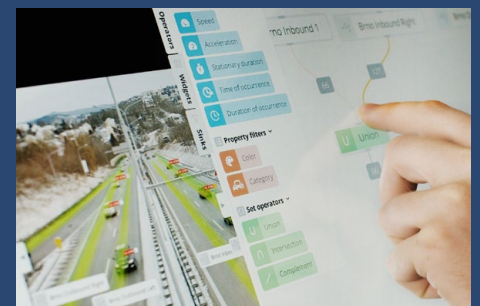

## Model

TrafficEmbedded unit  
Micro/Macro models

## Description

Real-time traffic analysis unit  
Vandal-proof  
On-Board processing

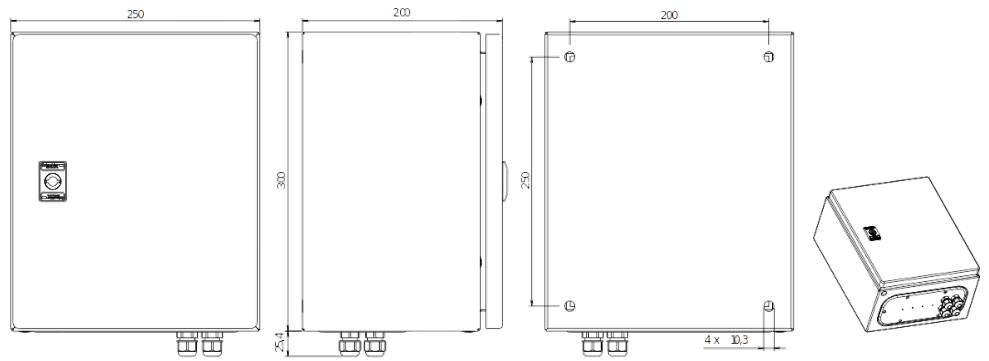

General properties:	Micro	Macro
Processor	Jetson Xavier NX	Jetson AGX Xavier
RAM Memory	8 GB RAM	32 GB RAM
Maximum consumption (without cameras)	40 W max	50 W max
Electrical Isolation	3Kv max	
Protection IP	IP66	
Dimensions	L300mm x H250mm x D250mm (without connectors)	
Weight	7.4 kg – whole outdoor design incl. the case	
Material	metal (aluminium)	
Designed for installation on:	wall, lamp post, poles and masts etc.	

Network and connectivity:	Micro	Macro
Number of connectable PoE cameras – (IEEE 802.3af, maximal power 30W/port)	2 ports	3 ports (standard) 6 (optional)
Optional Wi-Fi connectivity	IEEE 802.11 b/g/n	
Optional LTE modem	GSM (MHz) 900/850/1800/1900 UMTS (MHz) 900/2100 LTE (MHz) 800/1800/900/2600/2100	
Protocols	TCP, UDP, DHCP, DDNS, HTTP, HTTPS, NTP, RTSP	
Security	VPN, HTTPS, SSL version 3, AES, SHA	
Internal connectors	1x WAN RJ45, 3xPOE LAN RJ45	
Camera support	IP cameras with H.264 or H.265 codec and RTSP or ONVIF cameras	

Operating range	
Temperature	-20° – +60°C (-4° – +140°F)
Humidity	20 – 90% RH (non-condensing)

Storage range	
Temperature	-40° – +85°C (-40° - +185°F)
Humidity	10 – 95% RH

## Video Analysis Functions

- Detection and tracking of objects
- Category classification into 7 classes
- Maximum detection scale of 640x640 (Macro) or 460x460 (Micro)
- Minimum object size required for detection - 32x32 pixels
- Color recognition

## Traffic analytics & visualization functions

- Fully programmable trajectory processing and evaluation thanks to the FLOW framework
- Speed and stationary time measurement
- Customizable OpenAPI – REST/UDP/JSON format
- Customizable dashboards with interactive widgets

## Accessories/options:

- Battery power source 80 Ah, 130 Ah, 160 Ah
- IO expander – RS232, analog & digital inputs/outputs
- GNSS module
- Local storage – up to 1 TB for video data and traffic measurements
- GPS with the time server
- LoRa module – enables to convert Embedded to IoT device
- V2X module (C2X) - ETSI G5

RCE systems s.r.o.

Svatopluka Čecha 1d, 612 00 Brno, Czech Republic

 [datafromsky.com](http://datafromsky.com)

 [info@datafromsky.com](mailto:info@datafromsky.com)

 [/company/datafromsky](https://www.linkedin.com/company/datafromsky)