



## TrafficCamera

### Bullet-AN-8MP-40-100FOV-120WDR-30IR-POE

TrafficCamera is an outdoor bullet camera with **on-board video analytic engine FLOW**. It is an all-in-one **edge solution** enabling every feature of a distributed video-analytics environment for **smart traffic, parking, retail or security**. Thanks to the local processing it is **100% GDPR compliant** and has small bandwidth requirements.

The TrafficCamera is affordable, easy to set up and a highly reliable **multipurpose sensor** supporting **event based alerts** and **triggers**. Thanks to the **open API** it can be easily integrated with 3rd party **smart city systems and data platforms**. Connection and power are achieved with **POE**, and the camera is equipped with **IR** with a max distance of 30 meters for better low light vision and a fully motorized zoom allowing easy adjustment of the field of view from 40° to 110°. The camera also has **automatic updates** and can be configured remotely. Discover the next generation of **actionable video intelligence** packed into a single extremely versatile product - the TrafficCamera; your **plug and play sixth traffic sense**.

## Applications

TrafficCamera is an ideal choice for monitoring smaller areas or not so complex scenes such as two-lane roads, tunnels, pedestrian paths, entries or exits etc. Thanks to an onboard fully featured video analytic engine capable of processing and evaluating the extracted traffic data in a fully customizable way, it can send real-time alerts or directly control other connected devices including signs or gates. All statistics could be visualized on a camera dashboard. It is a fully functional stand-alone traffic monitoring solution without the need of a server-side part of its operation.

### Traffic violations detection

- wrong-way driving
- illegal lane change
- blocking vehicle detection

### Safety & security

- object presence alert
- suspicious behaviour detection

### Parking

- occupancy
- parking time
- wrong parking

### Traffic flow improvement

- congestion detection
- level of service measurement
- traffic statistics

### Retail

- queue detection
- heatmaps, stationary time
- measuring of attractiveness

### General:

- behavioural analysis
- counting / statistics
- occupancy / presence data

## Powered by FLOW, the most powerful traffic framework

FLOW is a fully interactive video analytical traffic framework designed for real-time driven applications. It is the fastest and the most efficient way to transform any video stream into a stream of actionable insights. The first tool ever which visualizes traffic data live right at your fingertips and communicates with the other parts of your smart infrastructure using open APIs. FLOW is built for all imaginable traffic scenarios thanks to the powerful combination of unique visual traffic programming language, trajectory-driven design and AI-based image processing. Take the advantage of the one unified solution for smart traffic, parking, retail and security, which runs everywhere.

### Video detection features

FLOW is powered by a proprietary developed and globally trusted video analytical engine utilizing deep-learning. This engine is capable of detecting and tracking hundreds of objects in multi-camera environments simultaneously.

### Interactive data visualization

FLOW allows you to visualize the extracted information and analyses using interactive widgets on the customizable dashboards. Create a beautiful live visualization of the current traffic situation composed from the histograms, heat-maps, trajectory views, graphs and other graphical elements.

### Traffic analysis functions

FLOW supports various traffic analytic functions and operators that can be combined into a comprehensive traffic analysis running in real-time. Thanks to the unique visual traffic programming language, you become the designer of a monitoring solution tailored to your specific needs.

### Data interfaces

FLOW was born for integration with other parts of smart infrastructure. Any type of extracted traffic insights can be continuously delivered to 3rd party systems using an open API which supports multiple communication protocols including UDP and REST.



## Model

TrafficCamera – AV

## Description

On-Board processing TrafficCamera  
8MP H.265  
Low Lux HDR  
Vandal-Proof

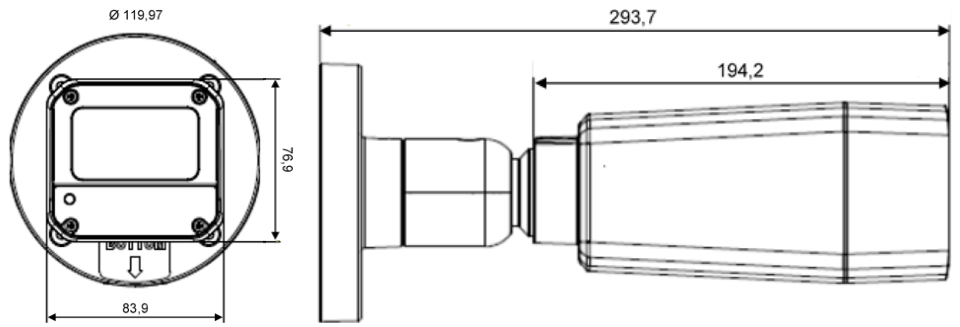

### Camera – general

Processor	Qualcomm QCS605
RAM Memory	4GB RAM/16GB eMMC
Power Supply	12V DC /24V AC/ POE+ (IEEE 802.3at) (max consumption 25.5W)
Image Sensor	1/1.8" progressive scan low lux CMOS
Picture Elements	3840 (H) x 2160 (V)
Minimum Illumination	0.025 Lux @F1.47 (Color), 0.02 Lux @F1.47 (B/W), 0 Lux (IR ON)
HDR/WDR	120 dB
Regulatory	CE, FCC, VCCI compliant, RoHS compliant, IP67, IK10
Dimensions	84 mm x 77 mm x 293 mm (with sunshield and bracket)
Weight	1.56Kg
Micro SD	Micro SD card slot, Pre-built SD: 16GB
LED Indicator	3 LEDs: Power, Status, Ethernet

### Lens

Day/Night	Yes (with removable IR-cut filter)
Lens Type	Motorized
Focal Length	4.46-11mm
Maximum Aperture	F/1.47
Horizontal FOV	40° ~ 110°
Image Format	1/1.8"
Max. IR Distance (Radius)	30m (98.43ft)

### Video capture parameters

Video Compression	H.265, H.264, MJPEG
Frame Rate	30 fps at 3840 x 2160
Audio Compression	G.711

### Network and connectivity

Interface	10/100 Ethernet
Protocols	TCP, UDP, DHCP, DDNS, HTTP, HTTPS, NTP, RTSP, SMTP, AMQP
Ethernet	RJ-45
Audio	Line in/Line out
Digital I/O	1 Input (Dry Contact), 2 Digital Output (Wet Contact)

### Storage, startup and operating conditions

Storage temp.	-30 °C ~ 60 °C (-22 °F ~ 140°F)
Storage humidity	10% ~ 90% (no condensation)
Startup temp.	-20 °C ~ 50 °C (-4 °F ~ 122 °F)
Operating temp. (IR off)	-30 °C ~ 50 °C (-22 °F ~ 122 °F)
Operating temp. (IR on)	-30 °C ~ 40 °C (-22 °F ~ 104 °F)
Operating humidity	10% ~ 90% (no condensation)

### Video Analysis Functions

- Detection and tracking of objects
- Category classification into 7 object types
- Detection scale of 320x320 pixels
- Minimum object size required for detection - 32x32 pixels in detection scale

### Traffic analytics & visualization functions

- Fully programmable trajectory processing and evaluation thanks to the FLOW framework.
- Speed and stationary time measurement
- Customizable OpenAPI - REST/UDP/JSON format.
- Customizable dashboards with interactive widgets
- Color recognition